



# User's Guide

# D0113MT-25-1302

# VFD- RoHS Compliant

(Vacuum Fluorescent Display Module)

---

For product support, contact

**Newhaven Display International, LLC**  
**2511 Technology Drive, #101**  
**Elgin, IL 60124**

Tel: (847) 844-8795 Fax: (847) 844-8796

*February 25, 2008*

# Vacuum Fluorescent Display Specification

**PART NUMBER:** D0113MT-25-1302

**FEATURES:** 13 Digits, 7-Segmented, Instrumentation

**APPLICATION:** Character Display (*7-Segmented*)

**RATINGS:** Below

<b>Outer Dimensions</b>	Panel Length	P.L.	129.0	mm	
	Panel Height	P.H.	25.0	mm	
	Panel Thickness	P.T.	7.5	mm	
<b>Leads</b>	Lead Pitch	L.P.	2.54	mm	
	Lead Out	-	SIL		
<b>Character Size</b>	Character Height	C.H.	9.6	mm	
	Character Width	C.W.	4.6	mm	
<b>Item</b>	<b>Symbol</b>	<b>Min.</b>	<b>Recommended</b>	<b>Max.</b>	<b>Unit</b>
<b>Filament Voltage</b>	Ef	4.4	4.9	5.3	Vac
<b>Peak Grid Voltage</b>	ec	-	25.0	30.0	Vp-p
<b>Peak Anode Voltage</b>	eb	-	25.0	30.0	Vp-p
-	tp	-	-	-	-
<b>Duty Cycle</b>	Du	-	1/17.5	-	-
<b>Pulse Width</b>	tp	-	80	-	uS
<b>Operating Temperature</b>	Topr	-20	-	+70	C
<b>Storage Temperature</b>	Tstg	-55	-	+ 80	C
<b>Color of Illumination</b>	Green				

**D0113MT-25-1302**

**Electrical  
Characteristics**

Item	Symbol	Test Condition	Min.	Typical	Max.	Unit
<b>Filament Current</b>	if	Ef = 4.9 Vac eb = ec = 0	94.0	104.0	115.0	mAac
	-		-	-	-	-
<b>Anode Current</b>	ib/1G~13G	Ef = 4.9 Vac eb = 25.0 Vp-p ec = 25.0 Vp-p Du = 1/17.5 tp = 80 uS	-	6.5	12.0	MAp-p
	-		-	-	-	MAp-p
	-		-	-	-	MAp-p
	-		-	-	-	MAp-p
	-		-	-	-	MAp-p
<b>Grid Current</b>	ic / 1G~13G		-	9.0	16.0	MAp-p
	-		-	-	-	MAp-p
	-		-	-	-	MAp-p
	-		-	-	-	MAp-p
	-		-	-	-	MAp-p
<b>Luminance</b>	L(G)		500	1000	-	cd/m <sup>2</sup>
	-		(146)	(292)	-	fL
<b>Luminance Ratio</b>	Lmin/Lmax		50	-	-	%
<b>Grid Cut-off Voltage</b>	Ecco	Ef = 4.9 Vac eb = 25.0 Vdc	-7.0	-	-	Vdc
<b>Anode Cut-off Voltage</b>	Ebco	Ef = 4.9 Vac ec = 25.0 Vp-p Du = 1/17.5 tp = 80uS	-5.0	-	-	Vdc

**Drive Mode = Dynamic State**

OUTLINE DRAWING (UNIT: mm)

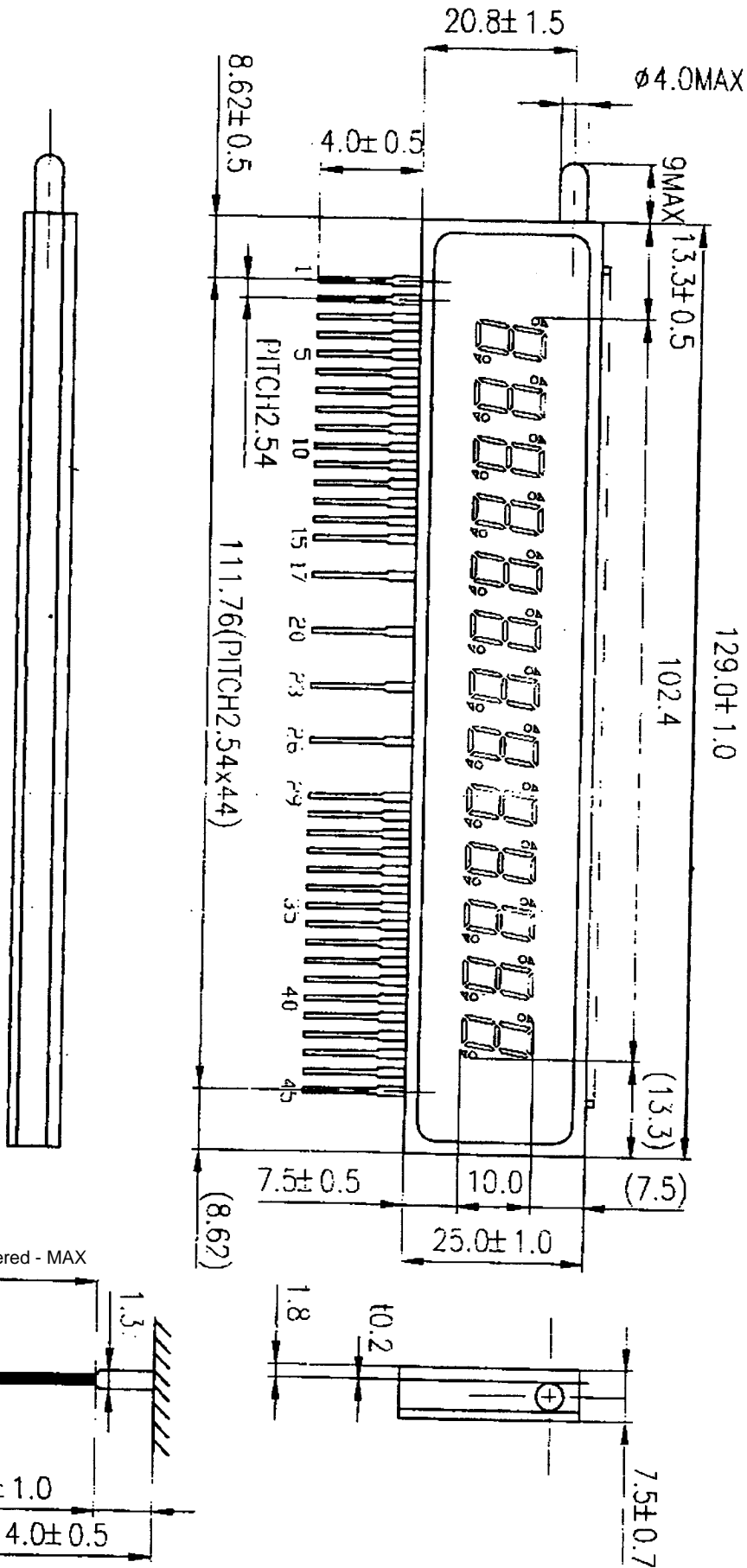

# TERMINAL CONNECTION

TERMINAL NO.	1	2	3	4	5	6	7	8	9	10	11	12	13	14	15
ELECTRODE	F	NC	NC	NC	13G	NC	NC	12G	P	P	11G	P	P	10G	P
TERMINAL NO.	16	17	18	19	20	21	22	23	24	25	26	27	28	29	30
ELECTRODE	NP	9G	NP	NP	8G	NP	NP	7G	NP	NP	6G	NP	NP	5G	P
TERMINAL NO.	31	32	33	34	35	36	37	38	39	40	41	42	43	44	45
ELECTRODE	P	4G	P	P	3G	NC	P	2G	P	NC	1G	NC	NC	NC	F
	(c)		(b)	(a)			(DP2)		(COM2)			(e)	(COM1)		(DP1)

Notes F:Filament NP:No Pin G:Grid NC:No Connection P:Anode

## PATTERN

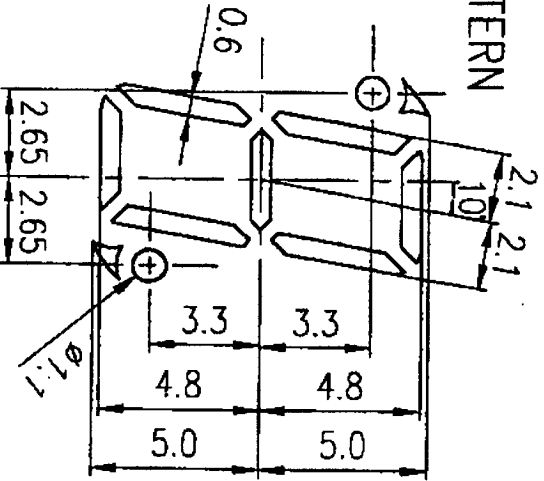

## SEGMENT DESIGNATION

